

PUMPSQUARE SYSTEMS LLP

PUMP

**PROVEN DESIGNS,
BETTER DESIGNED!!!**

Types of Pumps and its
Salient Features along with the
performance parameters



Call +91-800-00-PUMPS or +91-800-00-78677
for your pumping solution requirements !!!

KIESEL



KIESEL

The company G. A. Kiesel GmbH is a metalworking enterprise with a long tradition. Founded in 1864 as bell foundry, today we have changed into a medium-size family business, which produces armatures, pumps, and apparatus constructions. In 1988, new production and office space were based, in the industrial area Böllinger Höfe, in Heilbronn. This has since been expanded, and today

3700 m² of production space and 700 m² of office space and a highrack warehouse with 6000 storage spaces form the face of the company. A close co-operation with our customers and suppliers brings us new ideas for solutions to problems. Thus, today a trained staff offers a trans-industrial production range for many branches of industry. A CAD supported construction and planning department, manufacturing on modern CNC controlled production machines offer a wide range of products possible. A quality assurance system, in accordance with EN ISO 9001, guarantees a continuous high quality standard of the products.

Today, the KIESEL wine cellar technology program encompasses a comprehensive production. Beginning with valves made of stainless steel and brass, eccentric screw pumps, impeller pumps, mixers, heat exchanger and flotation and culminating to concentration equipment. By working closely with our customers in the past few years, the program for special machines has expanded. User-friendly machines have been developed, thanks to intensive tests and research.

G. A. Kiesel – Pumps Division in India is represented by us – Pumpsquare Systems LLP

PUMP

Pumpsquare Systems LLP is a young, dynamic company formed to cater the market needs of positive displacement pumps. Registered in April 2011, currently has an in class manufacturing and testing facility spread over 10,000 Sq. Ft. area. Using the cutting edge CNC Machining Center for producing pump components, it guarantees total interchangeability of components among the pump family and perfecting the products to meet the close tolerances for the pumps performance. Cutting edge 3-D CAD facility enables in providing you with customized solution and reducing the development time to the minimum.

Core strength of the company are its promoters as well as the unique structure of the company. Promoters include the combination of young generation with innovative minds and the older generation having more than 30 years of experience in selection, design, manufacturing and testing of positive displacement pumps. Whereas, unique structure formed is for sharing technology for the positive gain by the end user.

The ultimate goal of the company is to satisfy the customers need by providing the best possible solution.

You can find our pumps in the following industries:

- Chemical Industry
- Building Industry
- Pharmaceutical & Cosmetic industry
- Beverage & Food industry
- Varnish & Paint industry
- Sewage Technology

Only a few examples can be shown here where our pumps have admirably proved their worth. Our pumps are successfully used in many other branches of industry, as for example in agriculture, ship building, textile industries, paper industries and sugar refineries.

EL Pumps

KIESEL

KIESEL rotary lobe pumps are designed to achieve maximum pump performance combined with minimal product damage. Specific attention is paid to the bearing construction and the rigidity of the shaft. The design is kept as compact as possible and the volume between the lobes is optimized.

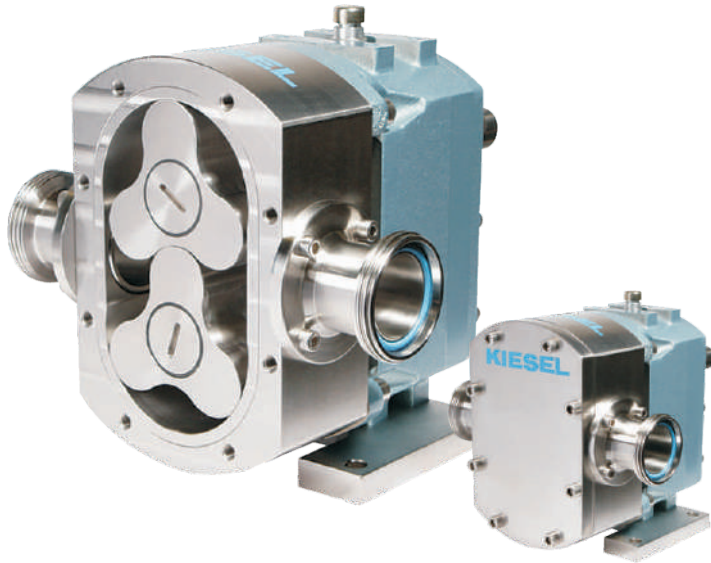

Advantages

- Non-Contact run of the pumping elements
- Simple and Fast demounting
- Perfect for hygiene application
- Robust and authentic design
- CIP/SIP Cleaning
- Complete Design
- Different, Harmonized rotors for special products

Specials

- Cover (in different materials) Available
 - Capable for use with abrasive media
- Capacity : 0,5 - 15 m³/h
Pressure : up to 12 bar
Temperature : up to 150°C
Viscosity : up to 160.000 mPas

IP Pumps

KIESEL

KIESEL impeller pumps are self-priming, rotating pumps. They unite the characteristic of a rotary pump and a positive displacement pumps into one.



Advantages

- All parts in stainless steel. Casings in Cast Iron & Mild Steel can be provided on request.
- Gentle, almost Pulsation-free conveyance
- Easy cleaning
- Simple and fast demounting
- Compact design, Low Weight
- Liquids with solids are pumped without problems
- Complete accessories program available

Pump Sizes : IP1 to IP30
Capacity : 1000 – 30 000 l/h
Max. Suction Lift : up to 5 m Ws
Max. Pressure Head : 4 bar
Max. Temperature : up to 130°C

SLP Pumps

KIESEL

KIESEL hose pumps are conceived for dosing and filling of puniest volume. At the assortment of the materials the great importance is set to the abrasion resistance.



Advantages

- Without Lubricants
- All product touched parts in stainless steel
- Easy Cleaning
- Simple and Fast Demounting
- FDA-conformable

Pump Sizes: SLP02 to SLP25
Capacity: 200 to 2500 l/h
Max. Suction Lift: up to 5 m Ws
Max. Pressure Head: approx. 2 bar
Max Temperature: approx. 100°C

SP / PC Pumps

KIESEL

KIESEL eccentric screw pumps are simply constructed in a unit construction. All the dimensions are laid out in such a way that the construction not only fits all the mechanical requirements but it has proved itself to give a long serviceable life. In selecting materials, great emphasis is laid on abrasion resistance.

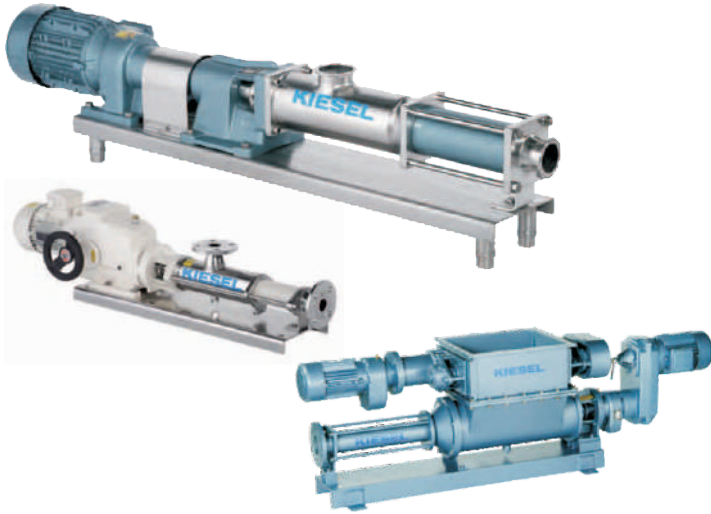

Advantages

- rotors with extreme high eccentricity thereby gentle conveyance
- hollow rotor, low vibrations, low weight
- easy cleaning
- CIP/SIP cleaning
- different material options for stators
- FDA-conformable
- compact ride able design
- complete accessories program available

Pump Sizes : SP02 to SP30

Capacity : 10 – 200 000 l/h

Max. Suction Lift: up to 6 m Ws

Max. Pressure Head: up to 24 bar

Max. Temperature: up to 145°C

Pumping Systems & Filters

We can engineer customized simplex and duplex pumping systems for lube and fuel oils complete with instrumentation, piping, and a skid mounted ready to install and commission.

We can also supply you with Simplex and Duplex Strainers tailor made as per your requirements

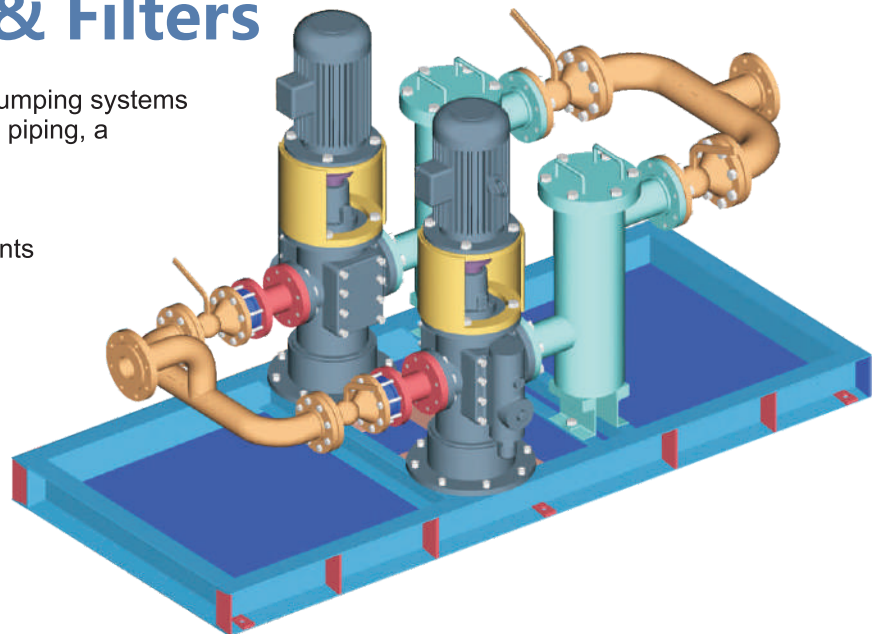

PUMP



IL Pumps

PUMPSQUARE internal lobe pumps are simple in design, uses gear in gear principle without the crescent. Shaft is rigidly supported for trouble free operation and longer service life. Liquid flow axially through the pumping element resulting in better suction than the gear pumps. These pumps come with built in relief valve.

Ex-stock Available!



Advantages

- High Volumetric Efficiency
- Low Power Consumption & Energy Efficient
- Specially developed material for Higher Rotor Life
- Pulsation Free Flow
- IL 1X pumps can be serviced without disconnecting pipelines and motors
- Lower Noise and Vibrations
- Easy to maintain, guaranteed interchangeability of parts on site.
- Foot, Flange, Foot cum Flange and Mono Block Pump Mounting Options

Pump Size : IL 01 to IL 16

Flow upto : 80 LPM

Max Pressure : upto 6 Kg/cm²

(12 Kg/Cm² in special cases)

Max Temperature : upto 120 deg C

Choice of Single Phase / Three Phase / DC Motor

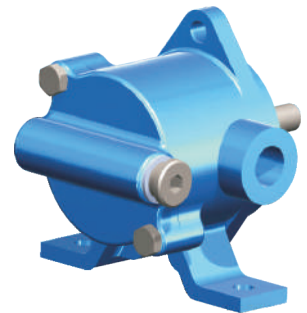
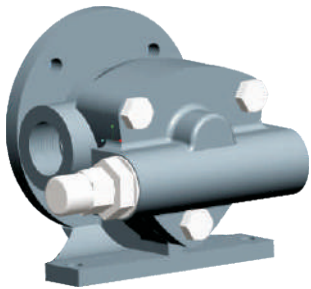

Applications

Ideal for unloading, transfer, forced lubrication and as booster pumps for handling fuel oils, lubricating oils, as well as other fluids with lubricating characteristics. Unidirectional flow designs for reversing shaft duties as in machine tools, gear boxes and crane duties.



IC Pumps

PUMPSQURE internal gear pumps uses Gear in Gear Principle with crescent shape partition. These pumps are designed for low NPSH requirements, self priming, bi-directional in most cases, and can be used to pump liquids with poor lubrication characteristics. They are insensitive to viscosity and pumps are excellent for high viscosity application.

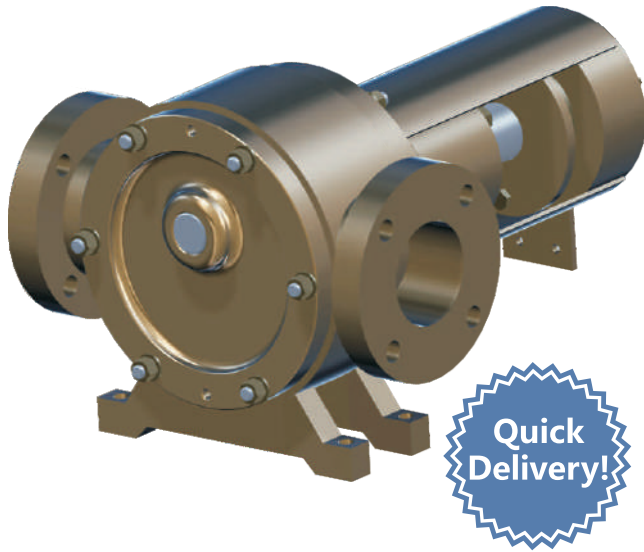

Advantages

- Choice of Wide Variety of MOC for pumps and rotors to match the compatibility of liquid pumped.
- Flexible Design – application customized.
- Overhung Design of Shaft, External Bearing enabling ease of access to pump
- Back Pull Design
- Low Pulsating Discharge
- Single adjustable end clearance
- Easy to maintain
- Can run dry for reasonable amount of time
- Slow Speed offers better pumping and longer life
- Liquid with poor lubrication characteristics can be pumped.

Port Size:	1" to 6"
Capacities:	up to 1000 LPM
Pressure:	up to 14 kg/cm ²
Operating Temperature:	up to 300 deg C
Viscosity:	up to 100,000 cSt
Relief Valve:	Optional / Integral
Jacketing:	Optional—Cooling / Heating
Shaft Sealing:	Gland Packing / Single or Double / Mechanical Seal / Lip Seal / Magnetically coupled
Mounting:	Bracket / Gear Box (Block Pump)
	V-Belt Drive / Gear Box / Geared Motor / Direct Drive / Mechanical Variator

TH Pumps

Pumpsquare Triple Screw Pumps are designed and engineered for excellent suction capability over a wide range of fluid viscosities. The self priming design permits both evacuation of air filled inlet and re-priming it if suction is lost. The three moving parts enclosed in the barrel are the key to pumps performance. The bores tolerances and the screw tolerances are so closely maintained that the back flow is minimized and the hydrodynamic thin film lubrication is maintained to reduce the wear. They pumps are silent, axial flow and are highly efficient.

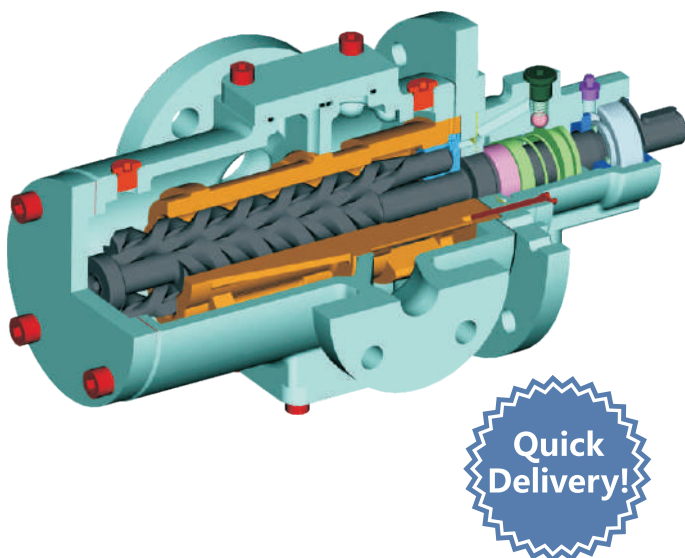

Applications

- Lubrication
- Circulation
- Fuel Firing
- Hydraulic Power Packs
- Transfer, Loading and Unloading

Specifications

- Flow upto 2500 LPM
- Pressure upto 120 Bar
- Temperature upto 180 deg C
- Viscosity upto 1500 cSt
- Pump Speed upto 3600 RPM
- Suited for continuous duty operations

Option Heating and Cooling Jacket.
Option of Horizontal and Vertical Mounting

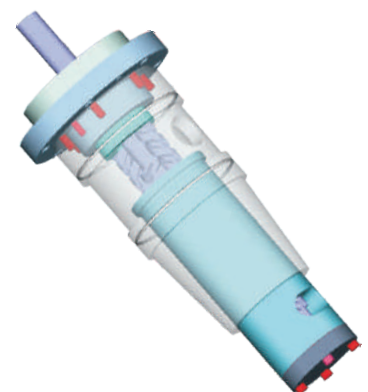

TW Pumps

PUMPSQUARE Twin Screw Pumps are designed for pumping contaminated or slightly abrasive liquid, lubricating and non lubricating media of low or high viscosity which do not chemically attack the pump materials. These are double entry pumps and the shaft spindle is axially held in position by ball bearings. Single unbalanced mechanical seal is used keeping the liquid pumped isolated from the bearings and gearbox. A spring loaded built in relief valve is used to protect the pump from overloading.

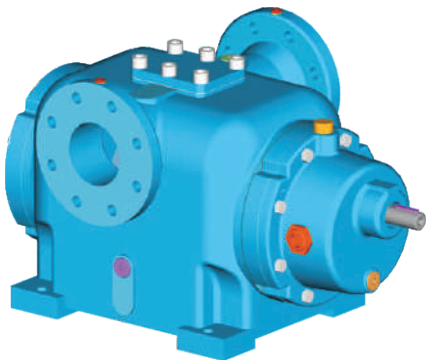
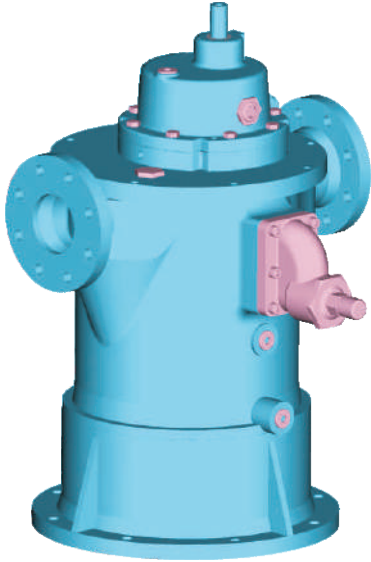

Performance Data

Capacity	Q	up to 535 m ³ /h
Viscosity Range	V	0,6 to 1500 cSt
Temperature of pumped Liquid	t	up to 100° C
Inlet Pressure	Ps	up to 10 bar
Outlet Pressure	Pd	up to 16 bar
Differece		
Pressure	Δp	up to 16 bar
Speed	n	up to 2900 rpm

Option Heating and Cooling Jacket.
Option of Horizontal and Vertical Mounting

Applications

Bilge/ballast Pumps
General Service Pumps
Cargo Pumps
Transfer Pumps

Spares and Services

With vast experience gained over a period of 30 years, we are also in a position to undertake consultation and servicing as well as supply of critical spares for well known pumps within the country as per the requirements of the end users.

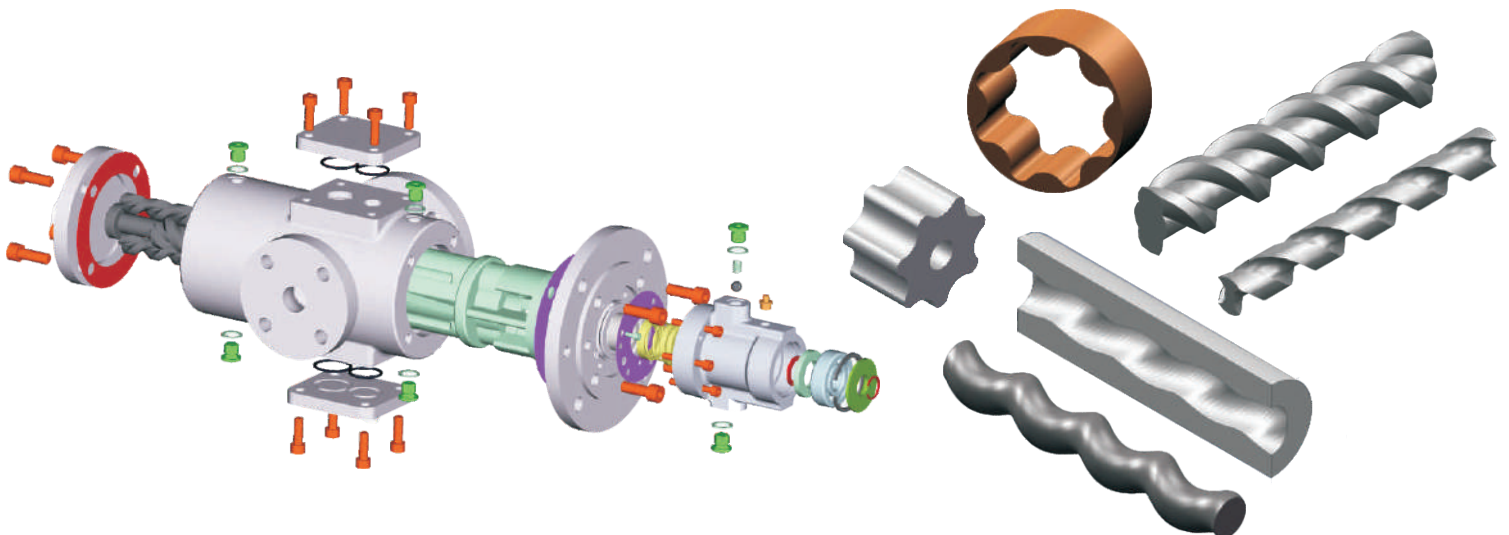



Triple Screw Pumps

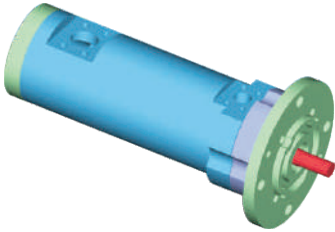

Triple Screw Pumps

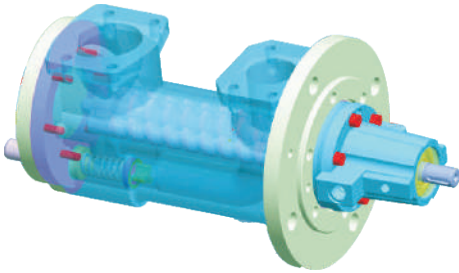

Triple Screw Pumps

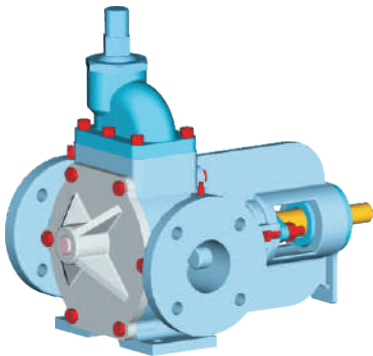

Shuttle Block Pumps

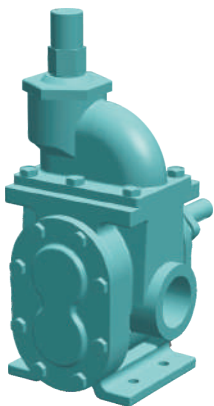

External Gear Pumps

At PUMPSQUARE
*We have only One Passion,
Giving You Right Pump for Right Application,
For, Right application like Yours*



PUMPSQUARE SYSTEMS LLP
Plot No 1903, Phase-IV, GIDC
Vitthal Udyog Nagar
Via Anand (Guj) 388 121
Contact # +91 93272 64813, +91 90049 67867
info@pumpsquare.com
www.pumpsquare.com